

**SH9450 SINGLE HUNG,  
TILT WINDOW,  
IMPACT RESISTANT, HVHZ,  
FLANGE, EQUAL-LEG & FIN FRAMES**

DP RATING	LARGE & SMALL MISSILE IMPACT RESISTANT
SEE TABLE 1	

TABLE 1: DESIGN PRESSURES

Buck Width	Buck Height	Max. Sash DLO Size (Width x Height)	Max. Fixed DLO Size (Width x Height)	Frame Type	Design Pressure	
					(+) psf	(-) psf
54"	76"	47.25" x 34.38"	49.75" x 34.5"	All	55.0	65.0
37"	62"	30.25" x 27.38"	32.75" x 27.5"	Flange, Equal-Leg	65.0	85.0

FOR SIZES NOT SHOWN, ROUND UP TO THE NEXT AVAILABLE WIDTH OR HEIGHT DIMENSION.

GLASS TYPE 2 MUST BE USED ABOVE 30 FEET IN THE HVHZ

1) THIS PRODUCT HAS BEEN DESIGNED & TESTED TO COMPLY WITH THE REQUIREMENTS OF THE FLORIDA BUILDING CODE, INCLUDING THE HIGH VELOCITY HURRICANE ZONE (HVHZ).

2) SHUTTERS ARE NOT REQUIRED WHEN USED IN WIND-BORNE DEBRIS REGIONS.

3) MASONRY ANCHORS MAY BE USED INTO WOOD. ALL WOOD BUCKS LESS THAN 1-1/2" THICK ARE TO BE CONSIDERED 1X INSTALLATIONS. 1X WOOD BUCKS ARE OPTIONAL IF UNIT IS INSTALLED DIRECTLY TO SUBSTRATE. WOOD BUCKS DEPICTED AS 2X ARE 1-1/2" THICK OR GREATER.

4) ANCHOR EMBEDMENT TO BASE MATERIAL SHALL BE BEYOND WALL DRESSING OR STUCCO. USE ANCHORS OF SUFFICIENT LENGTH.

5) MAX. 1/4" SHIMS ARE REQUIRED AT EACH ANCHOR LOCATION WHERE THE PRODUCT IS NOT FLUSH TO THE SUBSTRATE. USE SHIMS CAPABLE OF TRANSFERRING APPLIED LOADS.

6) THE ANCHORAGE METHODS SHOWN HAVE BEEN DESIGNED TO RESIST THE WIND LOADS CORRESPONDING TO THE REQUIRED DESIGN PRESSURE. THE 33-1/3% STRESS INCREASE HAS NOT BEEN USED IN THE DESIGN OF THIS PRODUCT. THE 1.6 LOAD DURATION FACTOR WAS USED FOR THE EVALUATION OF ANCHORS INTO WOOD. ANCHORS THAT COME INTO CONTACT WITH OTHER DISSIMILAR MATERIALS SHALL MEET THE REQUIREMENTS OF THE FLORIDA BUILDING CODE FOR CORROSION RESISTANCE.

7) FRAME FLANGES OR INTEGRAL FINNS MAY BE TRIMMED IN-FIELD TO CREATE AN EQUAL-LEG FRAME.

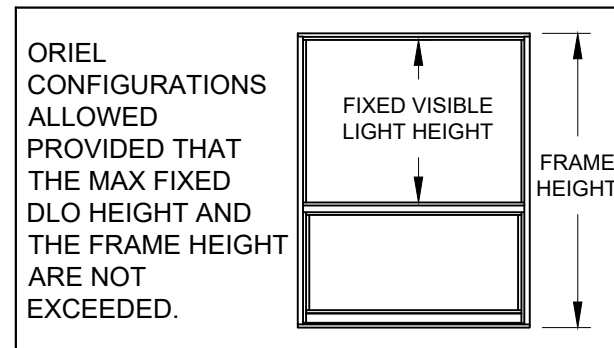
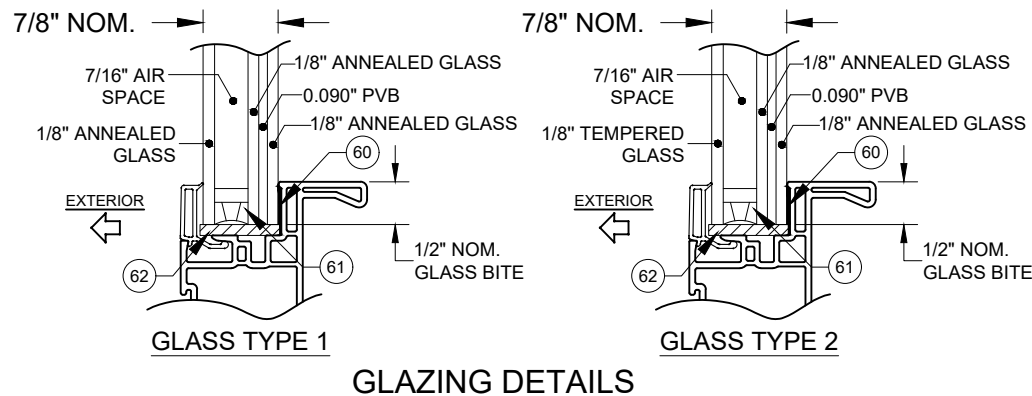
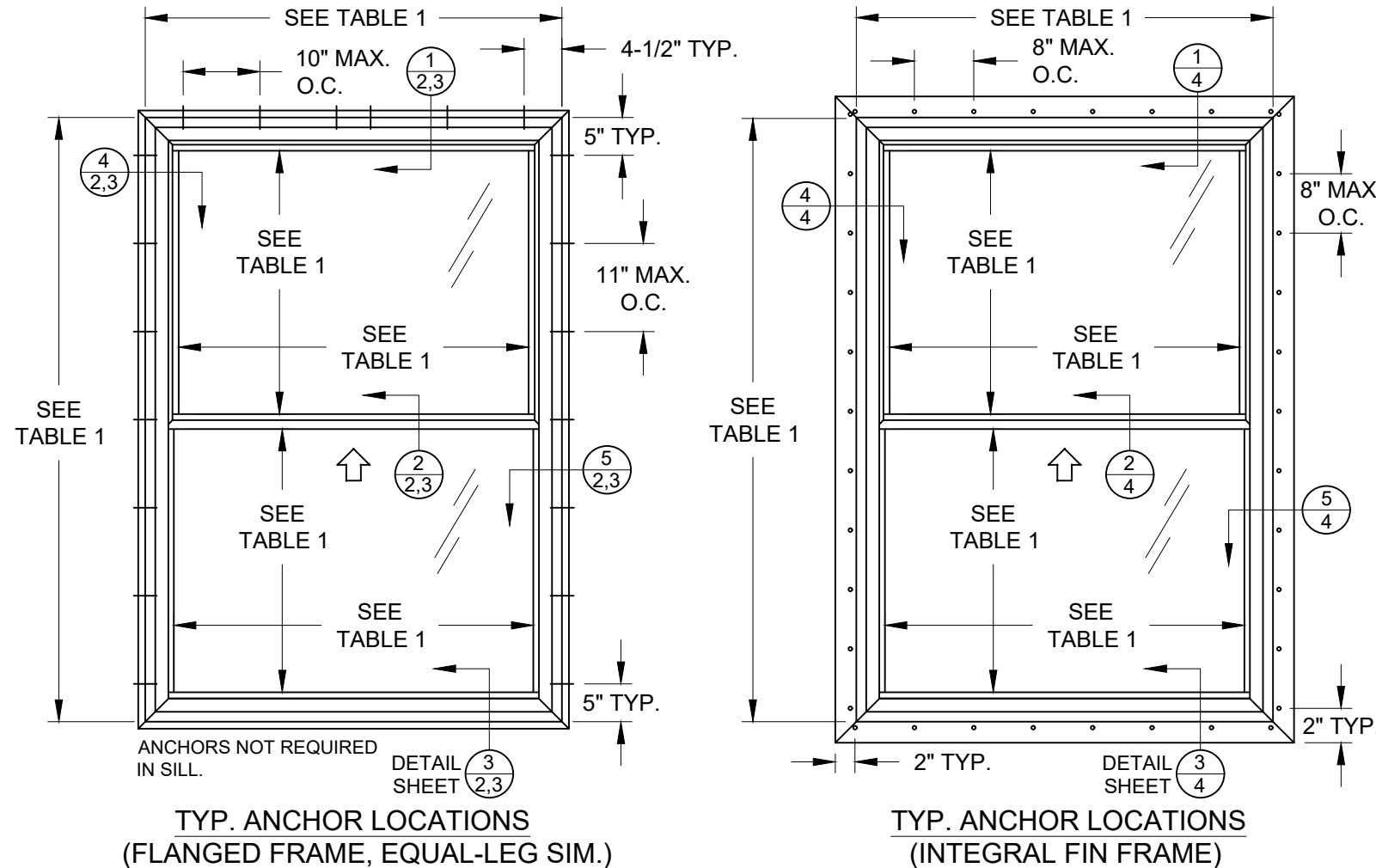

<p>PREPARED BY A. LYNN MILLER 1070 TECHNOLOGY DRIVE N. VENICE, FL 34275 (941) 480-1600</p>	<p>REGISTRATION #29296</p>	<p>DATE</p> <p>04/14/23</p>	<p>LOGAN YODER</p>
	<p>COPYRIGHT © 2023 NEWSOUTH SOLUTIONS TO MAKE COPIES FOR PERMITTING.</p>	<p>BY</p> <p>04/14/23</p>	
<p>NEWSOUTH SOLUTIONS 10741 CROSSROADS COMMERCE BLVD. TAMPA, FL 33610</p>	<p>NO.</p> <p>1 OF 5</p>	<p>SHEET</p> <p>1 OF 5</p>	<p>DESCRIPTION</p> <p>VINYL SINGLE HUNG WINDOW (LM - HVHZ)</p>
	<p>SERIES</p> <p>SH9450</p>	<p>TITLE</p> <p>ELEVATION &amp; GENERAL NOTES</p>	<p>DATE</p> <p>04/14/23</p>

A. LYNN MILLER, P.E.  
P.E.# 58705

Rev. # 08/18/23  
Date  
MINOR EDITORIAL UPDATES

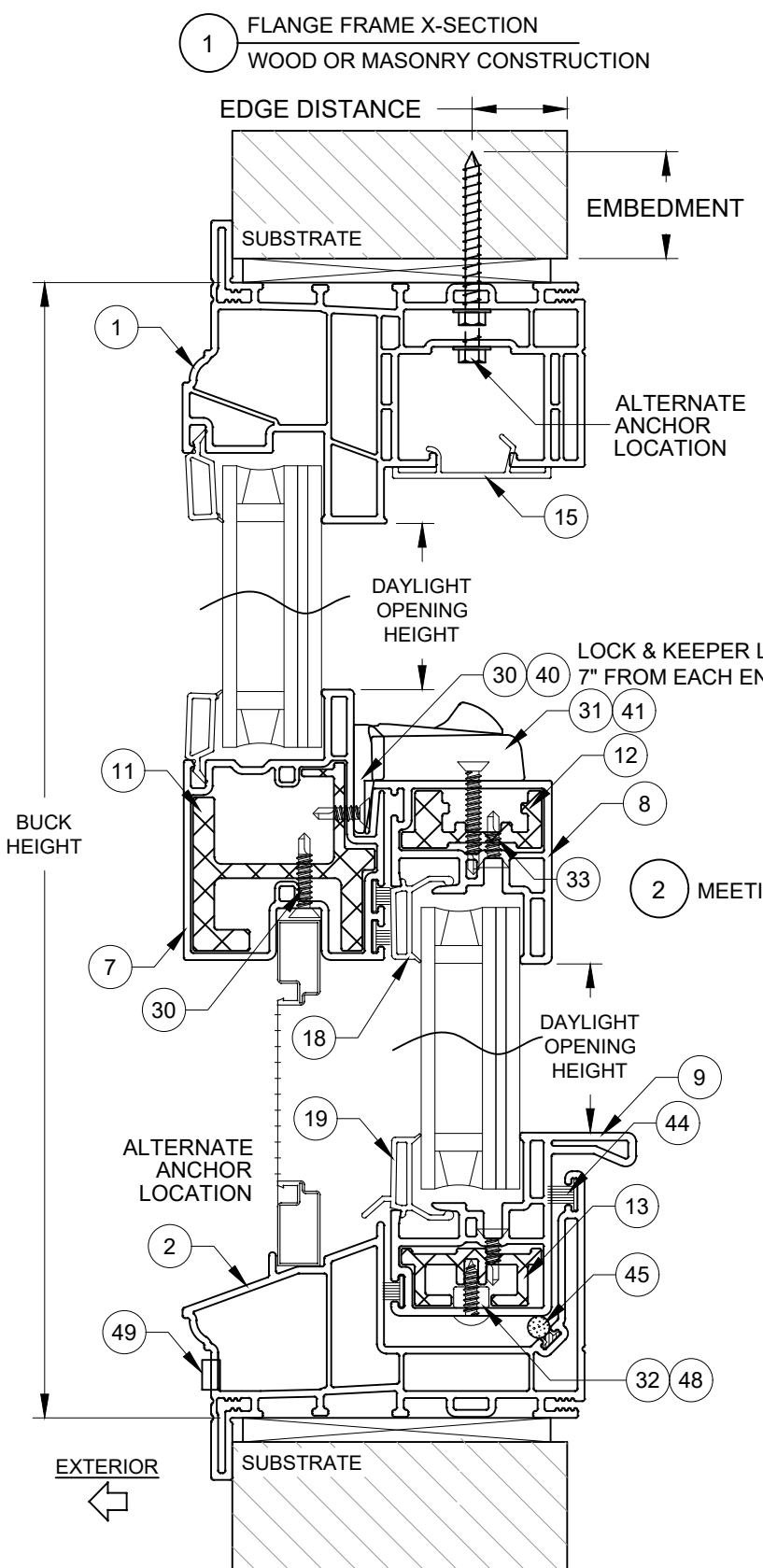

1 FLANGE FRAME X-SECTION  
WOOD OR MASONRY CONSTRUCTION

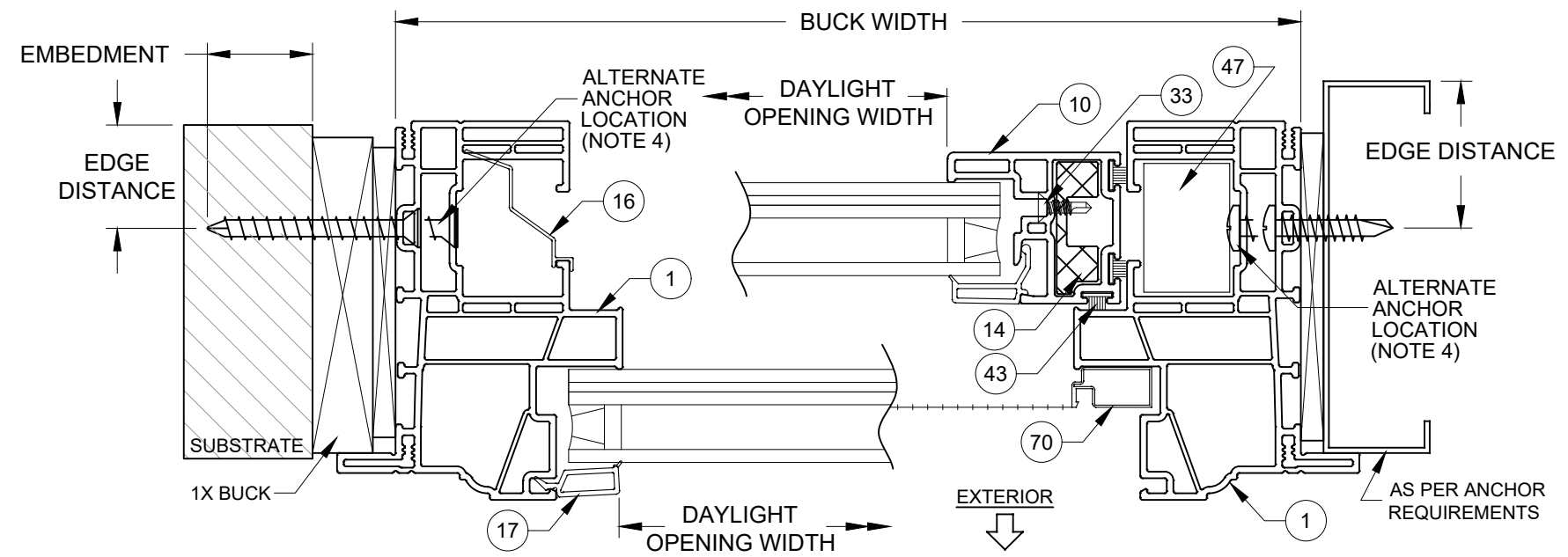

4 FLANGE FRAME X-SECTION  
USING 1X BUCK

5 FLANGE FRAME X-SECTION  
STEEL STUD CONSTRUCTION

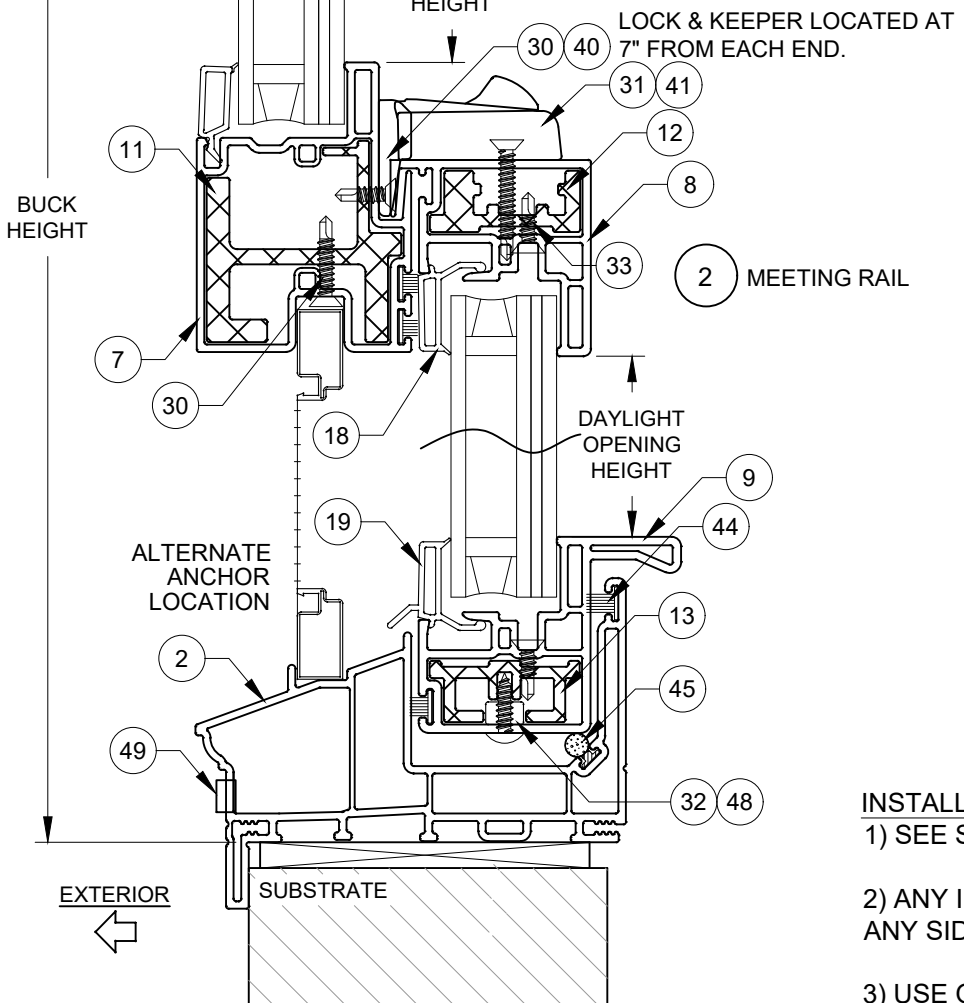

2 MEETING RAIL

TABLE 2: INSTALLATION ANCHORS

Anchor	Substrate	Minimum Edge Distance	Minimum Embedment
#10 or #12 Steel or 410 SS Screw	Southern Pine (SG = .55)	1/2"	1-3/8"
	Aluminum, 6063-T5 min.	5/16"	0.050"
	Steel Stud, Gr. 33 min.	5/16"	0.045" (20 Ga)
	A36 Steel	5/16"	0.050"
3/16" Steel Ultracon+	Concrete (min. 2.9 ksi)	1"	1-3/4"
	UngROUTED CMU, (ASTM C-90)	1-1/16"	1-1/4"
	Southern Pine (SG = .55)	1"	1-3/8"
1/4" Steel Ultracon+	Concrete (min. 3.0 ksi)	1"	1-3/8"
	UngROUTED CMU, (ASTM C-90)	1"	1-1/4"
	Southern Pine (SG = .55)	1"	1-3/8"

- 1) ANCHOR MUST EXTEND A MINIMUM OF 3 THREADS BEYOND ANY METAL SUBSTRATE.
- 2) "UNGROUTED CMU" VALUES MAY BE USED FOR GROUDED CMU APPLICATIONS.
- 3) ALL ANCHOR HEAD TYPES ARE APPLICABLE.

INSTALLATION NOTES:

- 1) SEE SHEET 1 FOR ANCHOR SPACING REQUIREMENTS.
- 2) ANY INSTALLATION OPTION SHOWN (2X BUCK OR WOOD FRAMING, 1X BUCK, DIRECT TO MASONRY, STEEL STUD) MAY BE USED ON ANY SIDE OF THE WINDOW.
- 3) USE ONLY SUBSTRATE APPROPRIATE ANCHORS LISTED IN ANCHOR TABLE 2. FOLLOW EMBEDMENT AND EDGE DISTANCE LIMITS. MAX. SHIM THICKNESS TO BE 1/4".
- 4) MAXIMUM DESIGN PRESSURE LIMITED TO +/- 55 PSF FOR ALTERNATE ANCHOR LOCATION.

Rev.# 08/18/23  
Date  
MINOR EDITORIAL UPDATES  
Rev.

PREPARED BY A. LYNN MILLER 1070 TECHNOLOGY DRIVE N. VENICE, FL 34275 (941) 480-1600	REGISTRATION #29296	04/14/23
	COPYRIGHT © 2023 NEWSOUTH SOLUTIONS TO MAKE COPIES FOR PERMITTING.	
	VINYL SINGLE HUNG WINDOW (LM - HVHZ)	LOGAN YODER
	FLANGE INSTALL SECTION VIEWS	SH9450-FPA-LM-HVHZ
NEWSOUTH SOLUTIONS 10741 CROSSROADS COMMERCE BLVD. TAMPA, FL 33610	2 OF 5	SH9450
Series Desc. Title	Sheet	DWG No.

ANTHONY LYNN MILLER  
LICENSE  
No. 58705  
08/17/23  
STATE OF FLORIDA  
PROFESSIONAL ENGINEER  
A. LYNN MILLER, P.E.  
P.E.# 58705

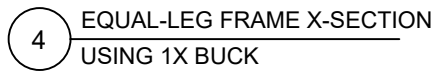
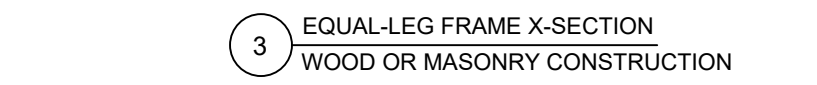
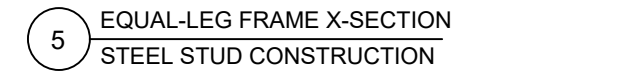
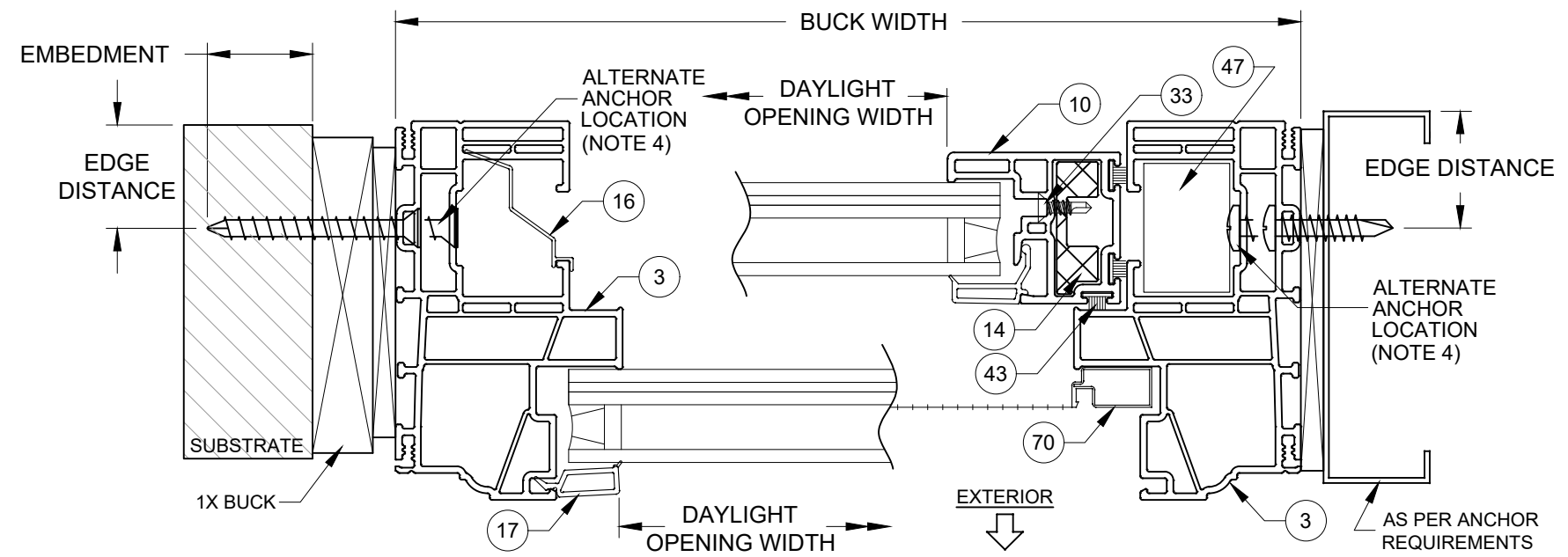
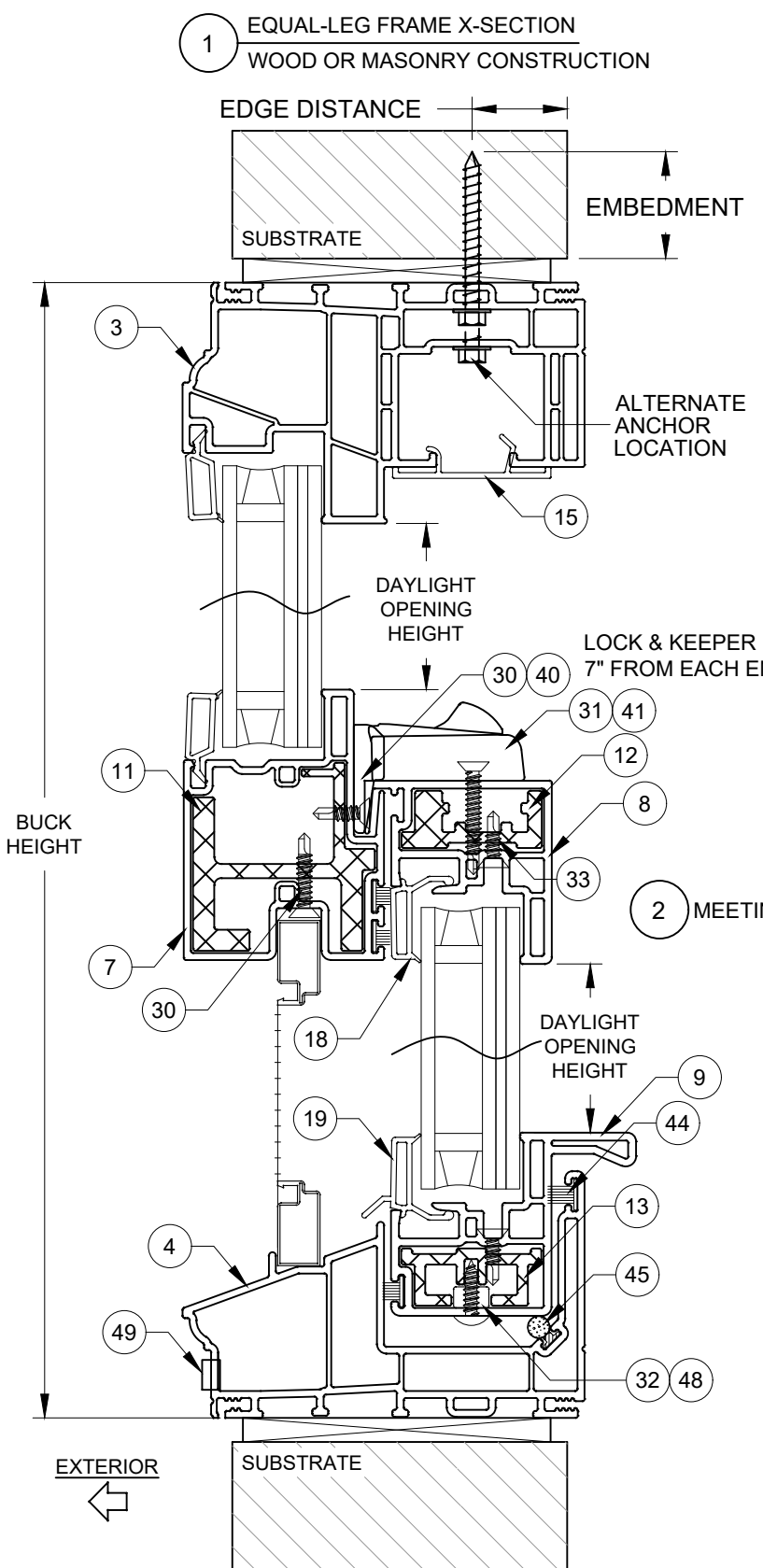

TABLE 3: INSTALLATION ANCHORS

Anchor	Substrate	Minimum Edge Distance	Minimum Embedment
#10 or #12 Steel or 410 SS Screw	Southern Pine (SG = .55)	1/2"	1-3/8"
	Aluminum, 6063-T5 min.	5/16"	0.050"
	Steel Stud, Gr. 33 min.	5/16"	0.045" (20 Ga)
	A36 Steel	5/16"	0.050"
3/16" Steel Ultracon+	Concrete (min. 2.9 ksi)	1"	1-3/4"
	UngROUTED CMU, (ASTM C-90)	1-1/16"	1-1/4"
	Southern Pine (SG = .55)	1"	1-3/8"
1/4" Steel Ultracon+	Concrete (min. 3.0 ksi)	1"	1-3/8"
	UngROUTED CMU, (ASTM C-90)	1"	1-1/4"
	Southern Pine (SG = .55)	1"	1-3/8"

- 1) ANCHOR MUST EXTEND A MINIMUM OF 3 THREADS BEYOND ANY METAL SUBSTRATE.
- 2) "UNGROUTED CMU" VALUES MAY BE USED FOR GROUDED CMU APPLICATIONS.
- 3) ALL ANCHOR HEAD TYPES ARE APPLICABLE.

INSTALLATION NOTES:

- 1) SEE SHEET 1 FOR ANCHOR SPACING REQUIREMENTS.
- 2) ANY INSTALLATION OPTION SHOWN (2X BUCK OR WOOD FRAMING, 1X BUCK, DIRECT TO MASONRY, STEEL STUD) MAY BE USED ON ANY SIDE OF THE WINDOW.
- 3) USE ONLY SUBSTRATE APPROPRIATE ANCHORS LISTED IN ANCHOR TABLE 3. FOLLOW EMBEDMENT AND EDGE DISTANCE LIMITS. MAX. SHIM THICKNESS TO BE 1/4".
- 4) MAXIMUM DESIGN PRESSURE LIMITED TO +/- 55 PSF FOR ALTERNATE ANCHOR LOCATION.

Rev.# 08/18/23  
Date  
MINOR EDITORIAL UPDATES  
Rev.

PREPARED BY A. LYNN MILLER  
1070 TECHNOLOGY DRIVE  
N. VENICE, FL 34275  
(941) 480-1600

REGISTRATION #29296  
COPYRIGHT © 2023 NEWSOUTH SOLUTIONS TO MAKE COPIES FOR PERMITTING.

NEWSOUTH SOLUTIONS  
10741 CROSSROADS COMMERCE BLVD.  
TAMPA, FL 33610

DATE: 04/14/23  
BY: LOGAN YODER  
DWC No. SH9450-FPA-LM-HVHZ  
Sheet 3 OF 5  
Series Desc. Title SH9450 EQUAL-LEG INSTALLATION SECTION VIEWS

ANTHONY LYNN MILLER  
LICENSE  
No. 58705  
08/17/23  
STATE OF FLORIDA  
PROFESSIONAL ENGINEER  
A. LYNN MILLER, P.E.  
P.E.# 58705

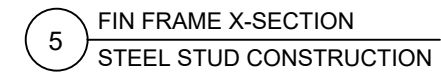
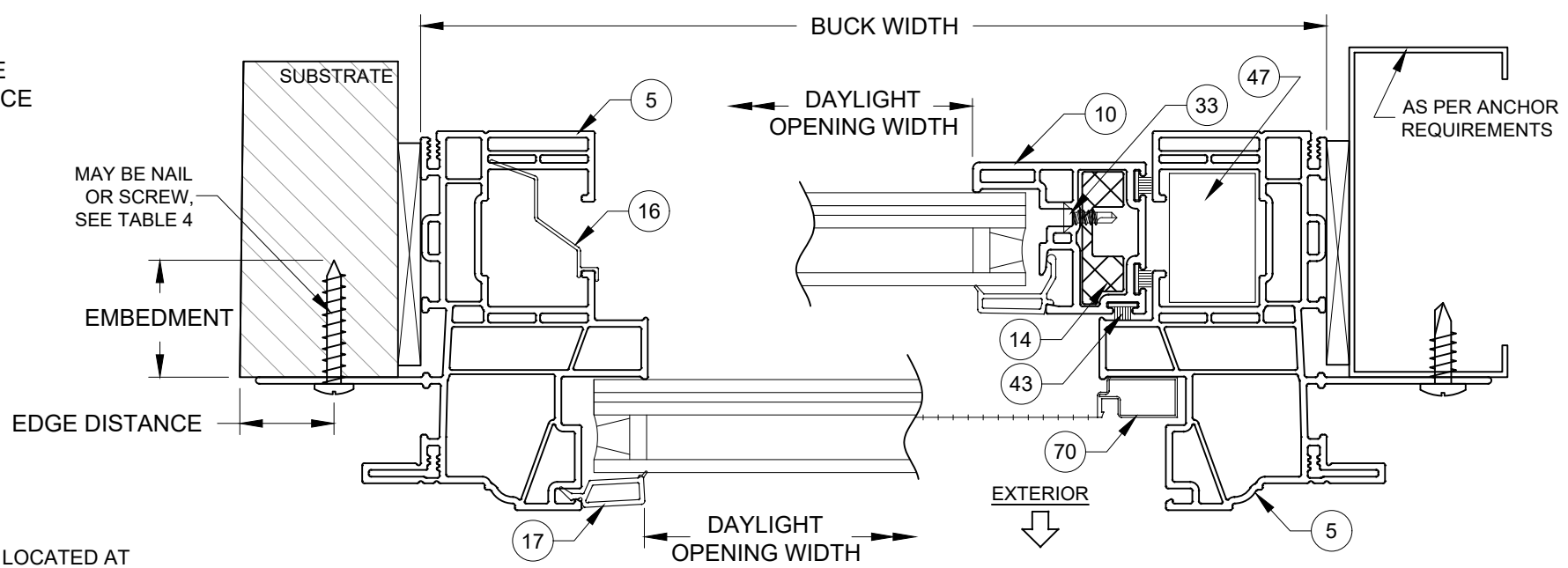
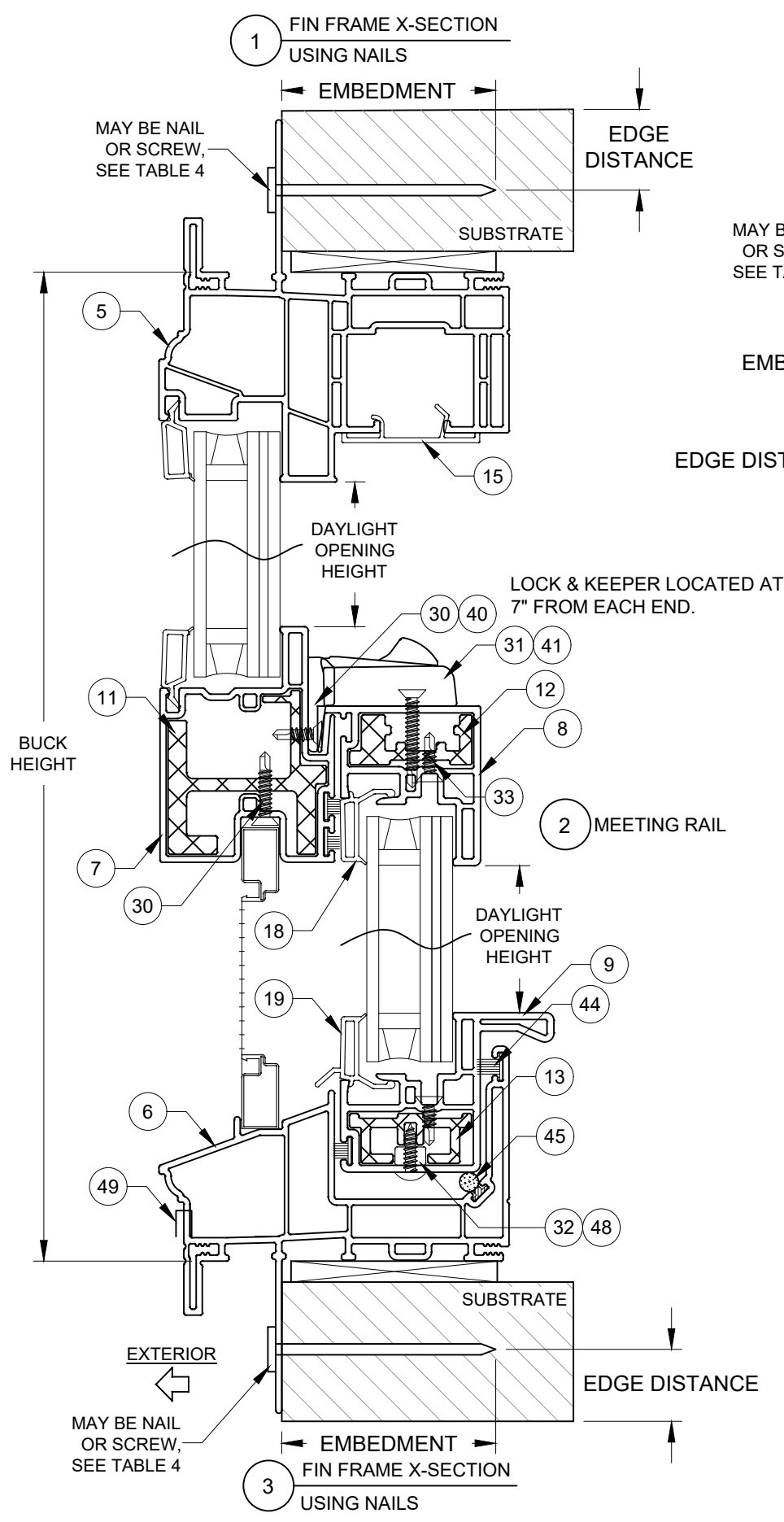

4 FIN FRAME X-SECTION USING SCREWS

5 FIN FRAME X-SECTION STEEL STUD CONSTRUCTION

HYBRID CONFIGURATIONS (FLANGE FRAME/FIN FRAME) ALLOWED WITH MULLION INSTALLATION, SEE PAGE 2 FOR FLANGE FRAME INSTALLATION DETAILS.

TABLE 4: INSTALLATION ANCHORS

Anchor	Substrate	Min. Edge Distance	Min. Embedment
2-1/2" x .113" Box Nail	P.T. Southern Pine (SG = .55)	5/16"	2-7/16"
2-1/2" x .131" Common Nail	P.T. Southern Pine (SG = .55)	3/8"	2-7/16"
2-1/2" x .145" Roofing Nail	P.T. Southern Pine (SG = .55)	3/8"	2-7/16"
#10 Steel SMS	P.T. Southern Pine (SG = .55)	1/2"	1-3/8"
	Aluminum, 6063-T5 min.	3/8"	1/8"
	Steel Stud, Gr. 33 min.	3/8"	0.036
	A36 Steel	3/8"	1/8"

1) ANCHOR MUST EXTEND A MINIMUM OF 3 THREADS BEYOND ANY METAL SUBSTRATE.  
2) ALL ANCHOR HEAD TYPES ARE APPLICABLE.

INSTALLATION NOTES:

- 1) SEE SHEET 1 FOR ANCHOR SPACING REQUIREMENTS.
- 2) FLANGE AND/OR FIN MAY BE REMOVED TO CREATE OTHER FRAME TYPES.
- 3) USE ONLY SUBSTRATE APPROPRIATE ANCHORS LISTED IN ANCHOR TABLE 4. FOLLOW EMBEDMENT AND EDGE DISTANCE LIMITS.
- 4) MAX SHIM THICKNESS TO BE 1/4". MAX SHIM SPACING TO BE 18".

PREPARED BY A. LYNN MILLER  
1070 TECHNOLOGY DRIVE  
N. VENICE, FL 34275  
(941) 480-1600

REGISTRATION #29296  
COPYRIGHT © 2023 NEWSOUTH SOLUTIONS TO MAKE COPIES FOR PERMITTING.

NEWSOUTH SOLUTIONS  
10741 CROSSROADS COMMERCE BLVD.  
TAMPA, FL 33610

VINYL SINGLE HUNG WINDOW (LM - HVHZ) 04/14/23  
FIN INSTALLATION SECTION VIEWS  
LOGAN YODER

SH9450 4 OF 5 SH9450-FPA-LM-HVHZ

ANTHONY LYNN MILLER  
LICENSE  
No. 58705  
08/17/23  
STATE OF FLORIDA  
PROFESSIONAL ENGINEER  
A. LYNN MILLER, P.E.  
P.E.# 58705

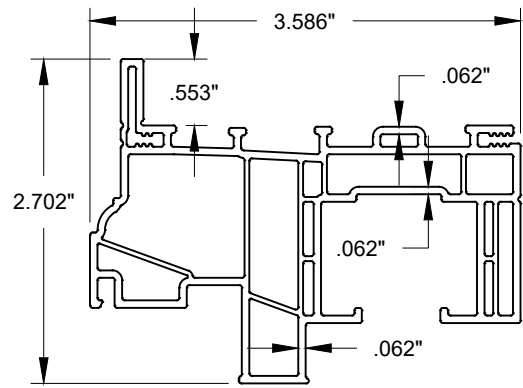

1 HEAD & JAMB, W/FLANGE

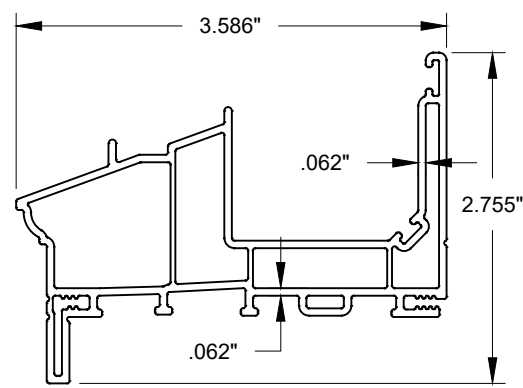

2 SILL, W/FLANGE

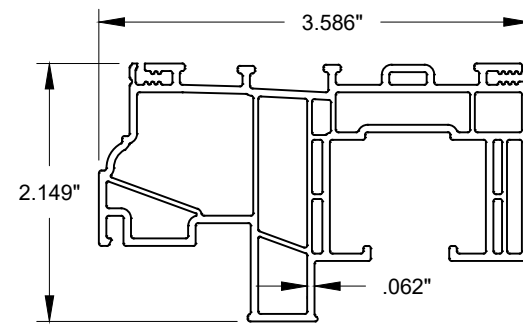

3 HEAD & JAMB, EQUAL LEG

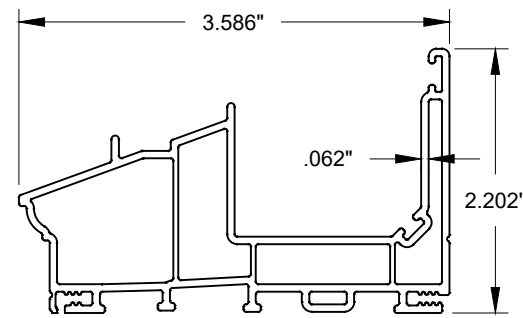

4 SILL, EQUAL LEG

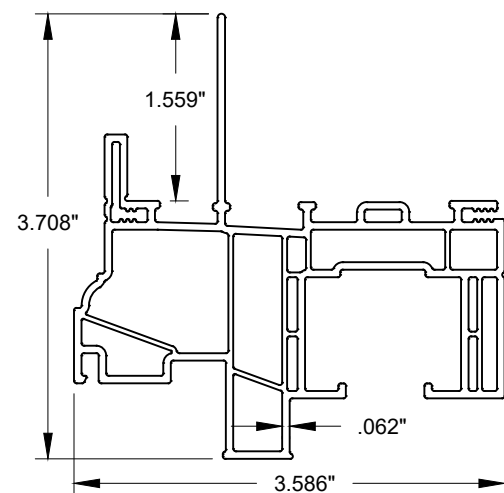

5 HEAD & JAMB, W/NAILING FIN

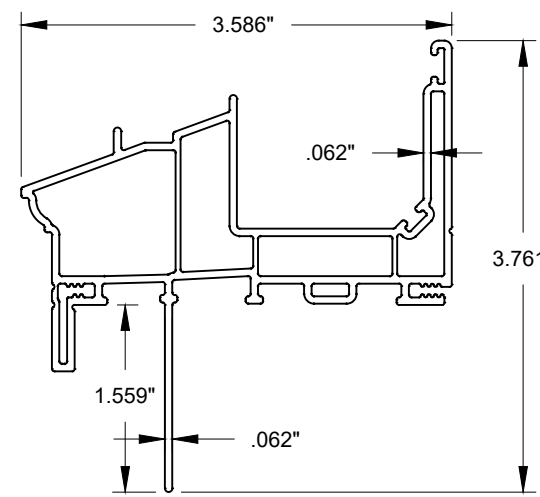

6 SILL, W/NAILING FIN

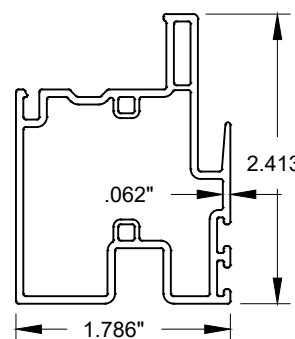

7 MEETING RAIL

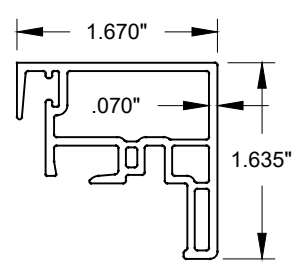

8 LOCK RAIL

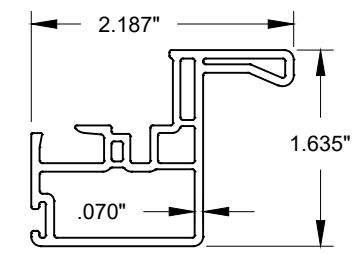

9 LIFT RAIL

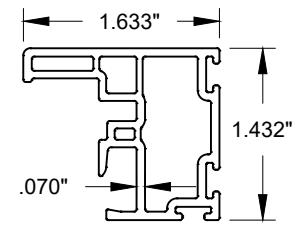

10 SASH STILE

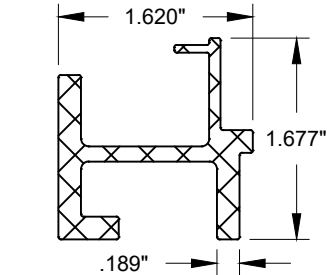

11 REINFORCEMENT (MEETING RAIL)

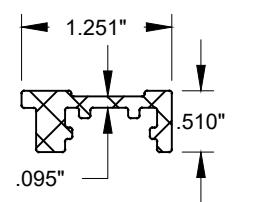

12 REINFORCEMENT (LOCK RAIL)

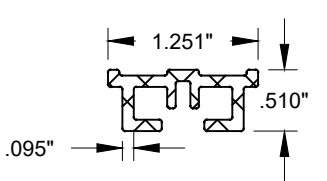

13 REINFORCEMENT (BOTTOM RAIL)

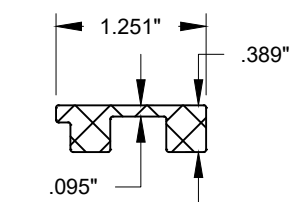

14 REINFORCEMENT (SASH STILE)

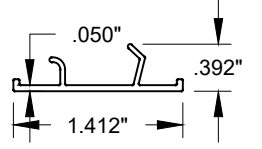

15 SASH STOP

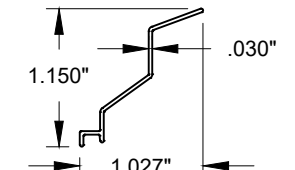

16 BALANCE COVER

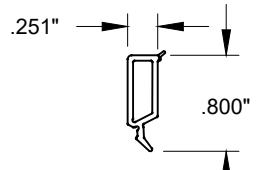

17 FIXED LITE GLAZING BEAD

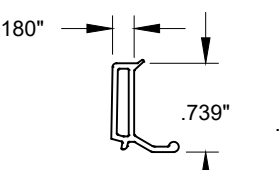

18 SASH GLAZING BEAD

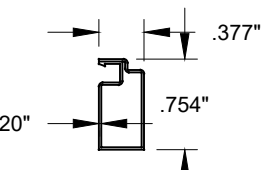

70 SCREEN FRAME

TABLE 5:

#	Part #	Description	Material
1	9465	Head & Jamb, w/Flange	PVC
2	9469	Sill, w/Flange	PVC
3	9465	Head & Jamb, Equal Leg	PVC
4	9469	Sill, Equal Leg	PVC
5	9455	Head & Jamb, w/Nailing Fin	PVC
6	9459	Sill, w/Nailing Fin	PVC
7	9477	Meeting Rail	PVC
8	9485	Lock Rail	PVC
9	9476	Sash Lift Rail	PVC
10	9438	Sash Stiles	PVC
11	6166	Reinf. - Meeting Rail	6063-T5
12	6165	Reinf. - Lock Rail	6063-T5
13	6163	Reinf. - Lift Rail	6063-T5
14	6164	Reinf. - Stiles	6063-T5
15	9473	Sash Stop	PVC
16	9468	Balancer Cover	PVC
17	9736	Fixed Lite Glazing Bead	PVC
18	9425	Sash Glazing Bead	PVC
30	1012	Screw, #6 x 3/4" PFH	Steel
31	1007	Screw, #6 x 1-1/8" PFH	Steel
32	1015	Screw, #8 x 1/2" PTRUSS	Steel
33	1003	Screw, #6 x 1/2" PFH	Steel
40	8096	Keeper	Zinc
41		Lock	
42	8121	MR Backing Plate	SS
43	4006	WSTP, .270" x .220" Polyfin	
44	4008	WSTP, .270" x .320" Polyfin	
45	4012	WSTP, Bulb Vinyl, .187" x .300"	Steel
46	8205/8206	Tilt Latch, L&R	Zinc
47		Balance	
48	8148	Pivot Bar	SS
49	8223	Weep Cover	Nylon
60		RGS 7700, Pecora 895, SikaFlex 552, Dow 791, 983 or 995	
61		Insulated Glass Spacer	
62	7061	Setting Block, 1/8" x 7/8" x 2"	EPDM
70	6244	Screen Frame	Aluminum

THE APPROVED, RIGID PVC EXTERIOR EXTRUSIONS ARE TO BE PRODUCED BY EXTRUDERS' LICENSEES UNDER "AAMA CERTIFICATION PROGRAMS FOR RIGID PVC EXTRUSIONS".

PREPARED BY A. LYNN MILLER  
1070 TECHNOLOGY DRIVE  
N. VENICE, FL 34275  
(941) 480-1600

REGISTRATION #29296  
COPYRIGHT © 2023 NEWSOUTH SOLUTIONS TO MAKE COPIES FOR PERMITTING.

NEWSOUTH SOLUTIONS  
10741 CROSSROADS COMMERCE BLVD.  
TAMPA, FL 33610

DATE: 04/14/23  
DRAWN BY: LOGAN YODER  
DATE: 04/14/23

VINYL SINGLE HUNG WINDOW (LM - HVHZ)  
EXTRUSIONS & BOM

NO. 5 OF 5  
SHEET 5 OF 5

SH9450  
SH9450-FPA-LM-HVHZ

ANTHONY LYNN MILLER  
LICENSE  
No. 58705  
A. Lynn Miller  
08/17/23  
STATE OF FLORIDA  
PROFESSIONAL ENGINEER  
A. LYNN MILLER, P.E.  
P.E.# 58705

Rev.# 08/18/23  
Date 08/18/23  
MINOR EDITORIAL UPDATES